

1G2HZ52LR1200001

MANUFACTURING COUNTRY	
1	U.S.A.

MANUFACTURER	
G	GM

DIVISION	
2	PONTIAC
3	OLDSMOBILE
4	BUICK

SERIES	MODEL	NAME
C	W	NINETY EIGHT REGENCY ELITE
C	X	NINETY EIGHT REGENCY
C	W	PARK AVENUE
C	U	PARK AVENUE ULTRA
H	X	BONNEVILLE SE
H	Z	BONNEVILLE SSE
H	N	EIGHTY EIGHT ROYALE LS
H	P	LESABRE CUSTOM
H	R	LESABRE LIMITED

BODY TYPES	
5	4 DOOR

SEQUENCE NUMBER	DIVISION
200001	PONTIAC
300001-80001	OLDSMOBILE
600001	BUICK

GM PLANT CODES	
H	FLINT
1	WENTZVILLE
4	ORION

MODEL YEAR	
S	95

CHECK DIGIT

V.I.N. CODE	R.P.O. CODE	ENG. TYPE	ENG. DESCRIPTION
K	L36	VC	3.8 MPI
L	L27	V6	3.8 MFI
1	L67	V6	3.8 SUPERCHARGED

RESTRAINT SYSTEM	
2	SIR DRIVER & PASSENGER ACTIVE BELTS

CHS0010A

Figure 3 - Vehicle Identification Number Explanation

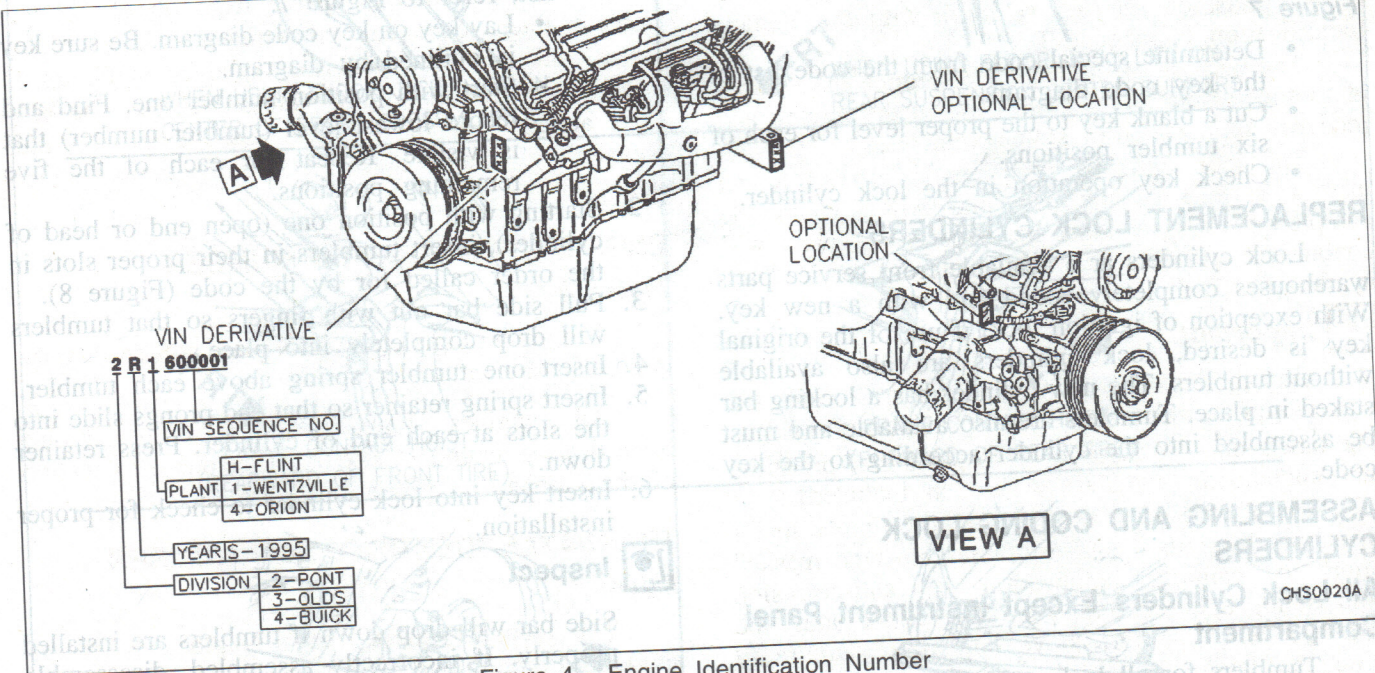

Figure 4 - Engine Identification Number

NOTICE: When jacking or lifting a vehicle at the frame side rails or other prescribed lift points, be certain that lift pads do not contact the catalytic converter, brake pipes or cables, or fuel pipes. Such contact may result in damage or unsatisfactory vehicle performance.

The centerline of gravity on front-wheel-drive vehicles is further forward than on rear-wheel-drive vehicles. Therefore, whenever removing major components from the rear of a front-wheel-drive vehicle while supported on a hoist, it is mandatory to support the vehicle in a manner to prevent the possibility of the vehicle tipping forward.